

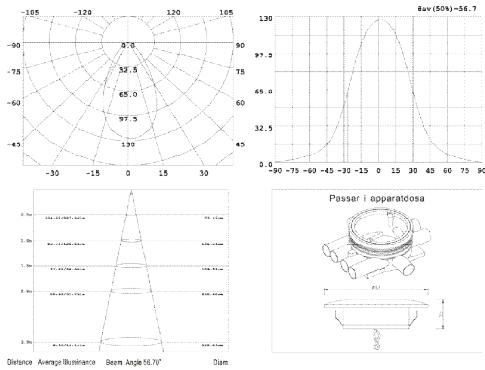



# LED - Leuchten

elektrogros ag  
LEUCHTENZUBEHÖR

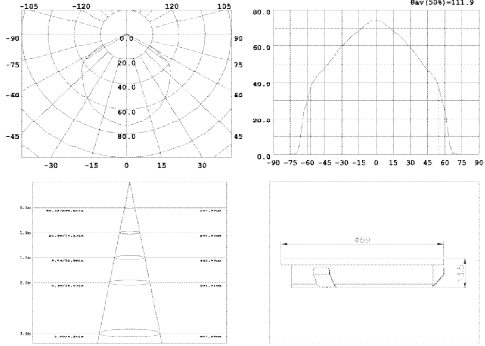

Bild		Artikel-Nr.	Beschreibung
	 <p>Distance Average Illuminance Beam Angle 56.7°</p>	<b>EGLUC1003 AL</b>	aluminium
		<b>EGLUC1003 MW</b>	matt-weiss
			Kelvin: 3000-3200K IP44 Lumen: 80 lm/w Winkel: 56,70° Durchmesser: 83 mm Einbautiefe: 25 mm Ausschnitt: 58 mm Betriebsstunden: 40'000
	LED LED TRAFU 3x1W 350mA IP44 H 25 mm 83mm Color temp. 3000-3200K 40000 CE RoHS		
	 <p>Distance Average Illuminance Beam Angle 111.9°</p>	<b>EGFLD1003 AL</b>	aluminium
		<b>EGFLD1003 MW</b>	matt-weiss
			Kelvin: 3000-3200K IP20 Lumen: 80 lm/w Winkel: 111.90° Durchmesser: 69 mm Einbautiefe: 13,5 mm Ausschnitt: 64 mm Betriebsstunden: 40'000
	LED LED TRAFU 3x1W 350mA IP20 H 13.5 mm 69mm Color temp. 3000-3200K 40000 CE RoHS		
	 <p>Distance Average Illuminance Beam Angle 111.9°</p>	<b>EGFLD1003-S AL</b>	aluminium
		<b>EGFLD1003-S MW</b>	matt-weiss
			Kelvin: 3000-3200K IP20 Lumen: 80 lm/w Winkel: 111.90° Durchmesser: 69 mm Einbautiefe: 20 mm Betriebsstunden: 40'000
	LED LED TRAFU 3x1.2W 350mA IP20 H 20 mm 69mm Color temp. 3000-3200K 40000 CE RoHS		

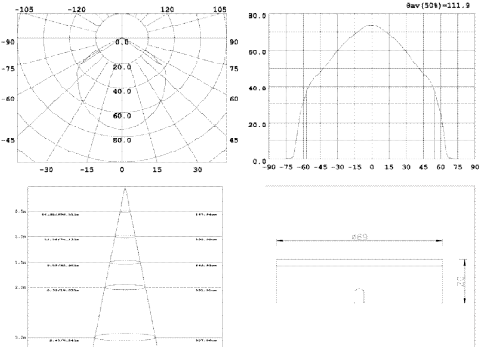
# LED - Leuchten

elektrogros ag  
LEUCHTENZUBEHÖR

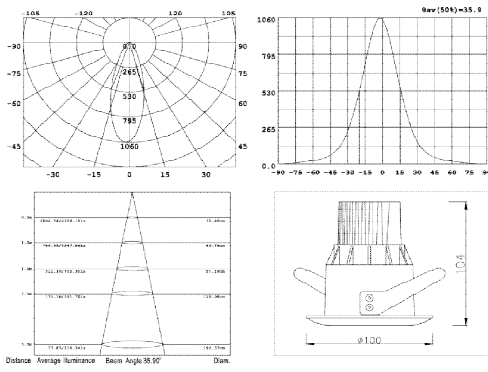

Bild		Artikel-Nr.	Beschreibung
			<b>LED-Einbau-Deckenleuchte mit 7W Sharp LED</b>
		<b>EGLDL4221 WH</b>	weiss
		<b>EGLDL4221 NM</b>	nickel
	<p>Distance Average Illuminance Beam Angle 35.9° Diam.</p> <p>SHARP LED LED DRIVER 7W 520mA F III 1058cd 85 lm/W</p> <p>IP44 68mm H 104mm 100mm Color temp. 3000 3200K 40000 CE RoHS</p>		<p>Kelvin: 3000K</p> <p>IP44</p> <p>Lumen: 85 lm/w</p> <p>Winkel: 35,90°</p> <p>Durchmesser: 100 mm</p> <p>Einbautiefe: 104 mm</p> <p>Ausschnitt: 68 mm</p> <p>Betriebsstunden: 40'000</p>

## 6-Weg-Verteilerbox

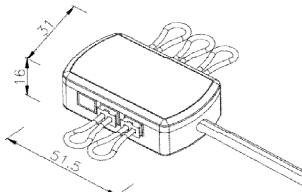
Bild		Artikel-Nr.	Beschreibung
			In Serie geschaltete Verteilerbox mit Kabel rot/schwarz, 15 cm Länge, mit Loop-Verbindern.
		<b>AF6FS</b>	weiss

## LED-Treiber für EGLDL4221

Bild		Artikel-Nr.	Beschreibung
			<b>Unabhängiger Stromversorger 10W mit konstantem Gleichstrom. Hohe Leistungsfähigkeit bei geringem Gewicht und Volumen. Konstanter Ausgangsstrom 500mA.</b>
		<b>PTDCC/10/500/B</b>	

gültig ab 01.02.2011

Die Preise sind in CHF und exklusive Mehrwertsteuer

Preisänderungen vorbehalten